

**EAST WIGHT COMBINED CLUBS
REGATTA SERIES 2026**

Lead Club

Supporting Club



MOCRA SERIES
6th & 19th April, 3rd, 4th, 17th & 18th May, 14th & 28th July, 13th
& 27th September, 11th & 25th October, 15th & 29th November,
13th December



WASZP GP OPEN
Saturday 9th & Sunday 10th May



PRINCE PHILIP'S CUP
Sunday 21st June



SWALLOW NATIONAL CHAMPIONSHIPS
Saturday 4th & Sunday 5th July



MOCRA NATIONAL CHAMPIONSHIPS
Monday 6th to Wednesday 8th July



SOLENT SCOW CHAMPIONSHIPS
Sunday 26th July



BEMBRIDGE VILLAGE REGATTA
Saturday 1st August



RS TERA & OPTIMIST OPEN REGATTA
Saturday 8th August



SVYC ILCA GRAND PRIX
Sunday 9th August



BEMBRIDGE SAILING CLUB REGATTA
Friday 14th and Saturday 15th August



J70 OPEN REGATTA
Saturday 15th & Sunday 16th August



SEA VIEW YACHT CLUB REGATTA
Sunday 16th and Monday 17th August



BRADING HAVEN YACHT CLUB REGATTA
Saturday 29th & Sunday 30th August



ROYAL VICTORIA YACHT CLUB REGATTA
(Merrydown Regatta)
Sunday 30th August



EAST WIGHT COMBINED CLUBS

www.ewcc.online

President	Jeremy Spencer-Cooper
Chairman	Polly Schafer
Hon Secretary	Mike Samuelson (<i>mikesam06@gmail.com</i>)

Bembridge Sailing Club (01983-872237) bembridgesailingclub.org sec@bembridgesailingclub.org	Interim Commodores (until 1 October 2026)	Colin Samuelson & Clare Chalmers
	Vice-Commodore	Vicks Wilson
	Rear-Commodores	Rory Morrison (Sailing) Dorian Maclean (House) Patrick Aylmer (Finance)
	Club Manager	Gemma Wall
	Sailing Manager	Laurence Blackburn
Brading Haven Yacht Club (01983-872289) bhyc.org.uk secretary@bhyc.org.uk	Commodore	Nigel Van Nuffelen
	Vice-Commodore	Jerry Summers
	Rear-Commodores	Grainne Andrews (On Water) Jan Baum (Onshore) Janet Snudden (Finance)
	Club Secretary	Rachel Occomore
Royal Victoria Yacht Club (01983-882325) office@rvyc.org.uk	Commodore	Jane Barrett Bellingham
	Vice-Commodore	Chris Gear
	Rear-Commodores	Peter Donaldson (Sailing) June Sabin (House)
	Hon Secretary	Cathy Kerr
	Hon Treasurer	Chris Gear
Sea View Yacht Club (01983-613268) secretary@svyc.org.uk training@svyc.org.uk	Commodore	Fiona Conway-Hughes
	Vice-Commodore	Sarah Rutherford
	Rear-Commodores	Jimbo Mitchell (Sailing) Guy Lawrence (House) James Eynon (Finance)
	Club Manager/Secretary	James Crofts
	Operations & Sailing Director	Jon Curtis

East Wight Combined Clubs exists as a Committee created jointly by Bembridge Sailing Club, Brading Haven Yacht Club, Royal Victoria Yacht Club and Sea View Yacht Club to co-ordinate the race management of keelboat and dinghy regattas organised by them in the Eastern Solent.

The Flag Officers of Bembridge Sailing Club, Brading Haven Yacht Club, Royal Victoria Yacht Club and Sea View Yacht Club invite all competitors and their supporters to be Associate Members and use the facilities of the Clubs during these Regattas.

ENTRY REQUIREMENTS FOR EAST WIGHT REGATTAS

Entrants for any race in the East Wight Series must have signed a 2026 Entry Form which includes agreement to be bound by the "Risk Statement" in EWCC SI 22 and that they consent to their entry details being held by the organising Club in accordance with that Club's Data Protection policy (see "Privacy Statement" in EWCC SI 23). By entering a race you are agreeing to follow the RYA anti-doping rules. To find out more click on: <https://www.rya.org.uk/club-centre-support/affiliates/club-anti-doping-guidance>

Entrants for handicap races will additionally be required to provide information about their boat and either a YTC or MOCRA rating certificate for cruisers and multihulls or for dinghies a Portsmouth Yardstick number.

Entry Forms will be available on request through Class Secretaries or from the Club Secretaries/Club Managers of the respective Clubs. The Entry Form for entrants under 18 **must** be endorsed by a parent/guardian.

Although BHYC, BSC, SVYC & RVYC follow common RYA Safeguarding standards, they have their own Safeguarding Policies which apply to their shore based and on the water activity. In the event of any safeguarding concerns during a Regatta, the nominated Welfare Officer of the lead Club shall be informed. Contact information for Club Welfare Officers and links to the lead Club's Safeguarding Policy are included in each NoR.

The Club Annual Entry Forms available from BHYC, BSC, SVYC & RVYC are applicable for any race in the East Wight Series. The respective clubs will, on request, provide the Organising Authority with a list of helms/boats in the specified classes who have validly signed an Entry Form. Entrants must also have paid the relevant entry fee, if any, prior to any race they enter.

Keelboats that appear in the vicinity of the Starting Line prior to their Preparatory Signal will be considered as Starters, provided they have complied with these entry requirements.

In addition to complying with these entry requirements, entrants in centreboard dinghies (including small multihulls) must sign the Sign-On Sheet for each race/event in which they compete in accordance with the requirements of the REGISTRATION & BRIEFING section of the relevant Notice of Race.

Clubs of the EWCC implement the RYA Racing Charter and competitors will be required to undertake to sail in compliance with the Charter, which can be found at the front of the RYA rule book (Racing Rules of Sailing 2025-2028) or at: <https://www.rya.org.uk/racing/rules/racing-charter>

In addition to the events included in this programme, some clubs will be running events to support the RYA 'Discover Sailing'. Additionally, supporting "Barts Bash" on Saturday or Sunday 12th/13th September.

NOTICES OF RACE & SAILING INSTRUCTIONS

Notices of Race and Sailing Instructions and Conditions of Entry can be downloaded from the EWCC website (www.ewcc.online) except for the following events which, whilst part of the East Wight Regatta Series, are governed by the Class Rules of their National Authority and will be issued separately; they can also be obtained from the organising Club or downloaded as shown below.

<i>EVENT</i>	<i>CLUB</i>	<i>WEBSITE</i>
WASZP GP Open	RVYC	https://racehub.waszp.com/eventdetail/489
Prince Philip's Cup	SVYC	www.svyc.org.uk
Swallow National Championships	SVYC	www.svyc.org.uk
IW Youth & Junior Dinghy Championships	BHYC & RVYC	www.iwyouthdinghychampionships.co.uk
Bembridge Illusion's 2026-2027	BSC	www.bembridgeillusionclassfleet.co.uk

2026 COURSES AND OTHER OPEN EVENTS

<i>Date</i>	<i>Courses</i>	<i>Host club(s)</i>	<i>Open events</i>	<i>Host club(s)</i>
18-19 Apr	PBL2 Course	RVYC		
27 May			SVYC v RVYC	SVYC
14 June	1st Aid Course	SVYC		
16 to 18 Jun	PB Instructors course	SVYC		
20 Jun	SRC Course	BSC		
21 Jun	Pre-Entry Dinghy Instrs	SVYC	Prince Philip's Cup	SVYC
22 to 26 Jun	DI course	SVYC		
6 to 10 Jul	DI Course	SVYC		
24 Jun		SVYC	SVYC v BHYC v RVYC v RSoLYC	SVYC
3 Jul	1st Aid	SVYC		
5 Jul	Pre Entry DI	SVYC		
6 Jul	PB Inst Skills Test	SVYC		
6 to 10 Jul	DI Course	SVYC		
7 to 9 Jul	PB Instructors course	SVYC		
12 Jul	Pre-Entry Dinghy Instrs	SVYC		
12 Jul	1st Aid Course	SVYC		
13 to 17 Jul	DI course	SVYC		
14 & 15 Jul	DI Multihull endorsement	SVYC		
15 & 16 Jul	Advanced DI course	SVYC		
17 Jul	Racing Instr Endorsement	SVYC		
23 Jul	SRC Course	BSC		
24 Jul	1st Aid Course	BSC		
22 Jul	Keelboat Inst Pre Entry	SVYC		
21 to 25 Jul	Keelboat Inst course	SVYC		
21 Aug			Scow Parade	BSC
12-13 Sept	PBL2 Course	RVYC		
13 Sep	1st Aid	SVYC		
4 Oct	1st Aid	SVYC		
8 Oct	SRC Course	SVYC		
10-11 Oct	PBL2 Course	RVYC		
24 Oct	1st Aid Course	BSC		
30 Oct	SRC Course	BSC		

RYA Interactive Courses - contact respective Club offices to find out how to enrol

SVYC - VHF (SRC); PPR; Essential Nav; CEVNI; Safe & Fun

BHYC - VHF (SRC); Safe & Fun

BSC - VHF (SRC); Safe & Fun

RVYC MOCRA OPEN SERIES 2026

6th & 19th April, 3rd, 4th, 17th & 31st May, 14th & 28th June, 19th July, 13th & 27th September, 11th & 25th October, 15th & 29th November, 13th December

NOTICE OF RACE

ORGANISATION

This event is part of the East Wight Combined Club's series. The Organising Authority will be RVYC.

CONDITIONS OF ENTRY & ENTRY FEE

Entrants must complete and return to the RVYC a 2026 Entry Form available from the RVYC website (<https://www.rvyc.org.uk>) or by e mail: office@rvyc.org.uk) before racing. This will include agreement to be bound to the "Risk Statement" in EWCC SI 22 and the "Privacy Statement" in EWCC SI 23 which can be downloaded from <https://www.ewcc.online>.

There is no entry fee.

All boats shall have a valid 2026 MOCRA Rating Certificate.

REGISTRATION & BRIEFING

Registration will be by radio (VHF Ch M1) to the RVYC Race Officer (call sign: VIC Race Officer) once entrants are in the vicinity of the race course.

There will be no briefing.

SAILING INSTRUCTIONS

Races shall be governed by the World Sailing Racing Rules of Sailing 2025 - 2028, RYA Prescriptions, MOCRA Rules, this Notice of Race and the Sailing Instructions. RVYC SIs will apply as varied by this Notice of Race. SI's can be downloaded from the RVYC website.

Unless modified by the RO before racing the Class Flag **M (MOCRA)** will be used 5 minutes prior to the start time.

PROGRAMME OF EVENTS (excl National Champs & RVYC Regatta)

Date	HW (<i>Portsmouth</i>)	Starts	Events
6 th & 19 th April	14:56 (4.3m); 13:22 (4.8m)		BH1 & MOCRA 1
3 rd & 4 th May	13:27 (4.4m); 14:04 (4.4m)		MOCRA 2 & BH2
17 th & 31 st May	12:18 (4.7m); 1:32 (4.3m)		MOCRA 3 & 4
14 th & 28 th June	11:13 (4.5m); 11:32 (4.2m)		MOCRA 5 & 6
19 th July	16:32 (4.7m)		Summer Cup
13 th & 27 th Sept	13:44 (4.8m); 12:40 (4.8m)		Autumn Cup & Autumn 1
11 th & 25 th Oct	12:37 (4.8m); 11:31 (4.7m)		Autumn 2 & 3
15 th & 29 th Nov	14:40 (4.1m); 14:41 (4.5m)		Autumn 4 & 5
13 th December	13:43 (4.3)		Autumn 6

SAILS, EQUIPMENT CHECKS & SAFETY

Boats shall comply with the current World Sailing Special Regulations for Category 4 races, except that regulations 3.13.1 (crash bulkheads), 3.15.2(c) and (d) (netting triangles), 3.14.4(c) (trimaran outrigger lines) and 3.14.4(d) (lifelines on catamarans) shall not apply. Spot checks to establish conformity with Class Rules may be made at the direction of the Race Committee before, during or after the series.

INSURANCE

Each participating boat shall be insured with valid third-party liability insurance with a minimum cover of £5,000,000.

COURSES & RACE FORMAT

The race course will be in the central and eastern Solent, between W Ryde Middle Buoy to the West and Kemps Quay buoy to the East. All racing marks will be on the 2026 RVYC Race Chart which can be downloaded from the RVYC website.

All races may be run as an Average Lap format at the discretion of the Duty Race Officer. For these races, competitors are required to repeat the course as notified to include the start/finish line at the end of each lap. Competitors will finish when the shortened course flag is displayed as they cross the start/finish line (irrespective of the number of laps completed). Clarification if necessary will be provided on VHF Ch M1.

STARTING

The start line will either use the RVYC race box, or a Committee Boat on the defined race course area.

Races will be started in accordance with RRS 26.

EXONERATION PENALTY, ADVISORY HEARING & RYA ARBITRATION

The exoneration Penalty and Advisory Hearing & RYA Arbitration of the RYA Rules Disputes Procedures will be available.

SCORING

Low Point Scoring System (RRS Appendix A) will apply. There will be one discard if 4 or more races are completed.

PRIZES

Providing there are sufficient entries, a trophy (provided by RVYC) will be awarded to the winner of the series, and will be presented at the MOCRA AGM and/or prize giving.

COMMUNICATIONS

Race Information - Ch M1; Race Management - M2 (P4);

BERTHING

Berthing can be arranged the night before, and/or after by contacting the RVYC Office.

MEALS

The RVYC bar and galley will be open at the times advertised on the website.

SAFEGUARDING

In the event of any concerns relating to Safeguarding during this Regatta, please contact RVYC's Welfare Officer (James Humphries) who can be contacted through the Club e-mail: office@rvyc.org.uk or on the Club landline number 01983 882325.

Jane Barrett Bellingham
Commodore, RVYC

Nigel Talbot
for MOCRA

EWCC MOCRA NATIONAL CHAMPIONSHIPS 2026

Monday 6th July to Wednesday 8th July

NOTICE OF RACE

ORGANISATION

This event is part of the East Wight Combined Club's series. The Organising Authority will be RVYC with support and assistance from BSC.

CONDITIONS OF ENTRY & ENTRY FEE

The Entry Requirements on page 2 of this programme, which includes agreement to be bound by the "Risk Statement" in EWCC SI 22 and the "Privacy Statement" in EWCC SI 23, apply. Both can be downloaded from <https://www.ewcc.online>. The Entry Form will be available from RVYC & BSC and must have been returned to the office@rvyc.org.uk by 29 June along with the Entry Fee of £120.00. There will be a surcharge of £20.00 for late entries received after 17:00 on 29 June. All boats shall have a valid 2026 MOCRA Rating Certificate.

REGISTRATION & BRIEFING

Registration and a briefing will be held at RVYC on Sunday evening 5th July at 18:30. Boats arriving on Monday morning prior to Race 1 must report in to the Committee Boat (SEA BREEZE) on arrival off Wootton (**Ch 77**).

SAILING INSTRUCTIONS

Races shall be governed by the World Sailing Racing Rules of Sailing 2025-28, RYA Prescriptions, MOCRA Rules, this Notice of Race and the Sailing Instructions. EWCC SIs will apply as varied by this Notice of Race. Rule 44.1 is changed so that the Two-turns Penalty is replaced by a One-turn Penalty. SIs can be downloaded from <https://www.ewcc.online>

The following Class Flags will be used: MOCRA - **M**

PROGRAMME OF EVENTS

Date & HW (Portsmouth)		Timings	Events
Sun 5th July	HW 15:58(4.4m)	On arrival (Wootton)	Registration at RVYC
		18:30	Briefing & Supper for those who are available at RVYC
Mon 6th July	HW 03:55 (4.2m) LW 09:19 (1.2m) HW 16:41 (4.3m)	12:00	MOCRA Race 1 (c 60 mins) - windward/leeward *
		oc	MOCRA Race 2 (c 60 mins) - triangle, sausage, triangle *
		15:30	MOCRA Race 3 (c 2 hours) - longer distance *
		oc	Overnight at RVYC pontoons/beach
		1930	BBQ at RVYC
Tues 7th July	HW 04:35 (4.1m) LW 10:06 (1.3m) HW 17:29 (4.3m)	10:00	MOCRA Race 4 (c 45 mins) – windward/leeward *
		oc	MOCRA Race 5 to Bembridge (3-4 hours) *
		oc	Overnight Bembridge Harbour
		19:15	Championship Dinner at BSC
Wed 8th July	HW 05:40 (4.1m) LW 11:01 (1.4m) HW 18:23 (4.12m)	09:00	MOCRA Race 6 (c 60 mins) - windward/leeward *
		oc	MOCRA Race 7 (c 60 mins) - triangle, sausage, triangle *
		oc	MOCRA Race 8 (c 2 hours) - windward/leeward *
		oc	To home Ports

** Format and duration of races may be modified by the RO*

SAILS, EQUIPMENT CHECKS & SAFETY

Boats shall comply with the current World Sailing Special Regulations for Category 4 races, except that regulations 3.13.1 (crash bulkheads), 3.15.2(c) and (d) (netting triangles), 3.14.4(c) (trimaran outrigger lines) and 3.14.4(d) (lifelines on catamarans) shall not apply. Spot checks to establish conformity with Class Rules may be made at the direction of the Race Committee before, during or after the Regatta.

COURSES & RACE FORMAT

A list of all likely marks with GPS co-ordinates will be e-mailed to competitors separately; inflatable marks may be used. EWCC Special Courses 1, 5 or 6 may be used. When racing off Bembridge, Boats shall not pass between St Helens Fort and Nodes Point during racing.

Where appropriate, scoring races will be run as an Average Lap format for MOCRA boats. For these races, competitors are required to repeat the course as notified to include the start/finish line at the end of each lap. Competitors will finish when the shortened course flag is displayed as they cross the start/finish line (irrespective of the number of laps completed). Clarification if necessary will be provided on VHF Ch 77.

STARTING

Races will be started in accordance with RRS 26 modified so that the Warning Signal for each MOCRA start shall be displayed 10 mins before the Start; the Preparatory Signal will be displayed 4 mins before the Start.

TIME LIMITS

In addition to the time limits in EWCC SI 14, there will be an additional time limit of 1 hour to reach the first mark. EWCC SI 14.1 is changed to 5 hours for Race 5.

EXONERATION PENALTY, ADVISORY HEARING & RYA ARBITRATION

The exoneration Penalty and Advisory Hearing & RYA Arbitration of the RYA Rules Disputes Procedures will be available. This extends SI 15.

SCORING

Low Point Scoring System (RRS Appendix A) will apply. Three races will constitute a Series. There will be one discard if 5 races are completed and two discards if all 8 races are completed.

PRIZES

MOCRA National Championship Trophies will be presented at the MOCRA AGM & Dinner later in the year.

COMMUNICATIONS

Race Information - Ch 77; Race Management - M2; Bembridge Harbour/Marina - Ch 80. SI 20.1 is modified to "VHF and Mobile Phones may not be used to obtain information not publicly available." A competitors WhatsApp group will be established.

BERTHING

Berthing requirements at RVYC must be indicated on the Entry Form; bookings for Bembridge Harbour must be made direct with the Harbour Company (01983 872828) - quote Rally RV77 - and should be made by 16 June 2026, otherwise will be on an 'as available' basis.

MEALS

Meal requirements for the Regatta should be entered on the back of the Entry Form. These must be confirmed and paid for prior to arrival at RVYC and BSC.

INSURANCE

Each participating boat shall be insured with valid third-party liability insurance with a minimum cover of £5,000,000.

SAFEGUARDING

In the event of any concerns relating to Safeguarding during this Regatta, please contact either BSC's Welfare Officer (Gemma Wall) who can be contacted on gemma@bembridgesailingclub.org or on the Club landline 01983 872237, or RVYC's Welfare

Officer (James Humphries) who can be contacted through the Club e-mail: office@rvyc.org.uk or on the Club landline number 01983 882325.

ANTI - DOPING

By entering a race, participants agree to follow RYA anti-doping rules. More details of RYA Sail Clean are available by clicking *here*.

CANCELLATION/REFUNDS

Entry Fee, Berthing at RVYC & Meals in full if cancelled a week before the start of the Championships. 50% up to 3 days before and 0% if cancelled within the final 72 hours.

Jane Barrett Bellingham
Commodore (RVYC)
BSC

Rory Morrison
Rear Commodore (Sailing),

SOLENT SCOW CHAMPIONSHIP

Sunday 26th July

NOTICE OF RACE

<i>HIGH & LOW WATER PORTSMOUTH (BST)</i>		
	HW	LW
Sunday 26 th July	10:27 (3.9m)	15:38 (1.9m)

ORGANISATION

This event is part of the East Wight Combined Clubs' Series. The Organising Authority will be BSC with race management assistance provided by BHYC.

ELIGIBILITY & ENTRY

Helms must be members of an affiliated RYA Club. The Entry Requirements on page 2 of this programme, which includes agreement to be bound by the "Risk Statement" in EWCC SI 22 and the "Privacy Statement" in EWCC SI 23, apply. There is no Entry Fee.

REGISTRATION & BRIEFING

In addition to complying with the entry requirements, entrants **must sign the Sign-On Sheet at BSC or BHYC at least 30 minutes before the scheduled race start time.** Failure to do so will result in the boat not being recognised as racing. There will not be a briefing.

RULES & SAILING INSTRUCTIONS

Races shall be governed by the World Sailing Racing Rules of Sailing 2025-2028, RYA Prescriptions, Class Rules, this Notice of Race and the Sailing Instructions. Races will be sailed under the East Wight Sailing Instructions, as varied by this Notice of Race. They can be downloaded from <https://www.ewcc.online> Class flags are as shown below. Races will be started in accordance with RRS 26. Rule 44.1 is changed so that the Two-turns Penalty is replaced by a One-turn Penalty.

PROGRAMME OF EVENTS

Date	Race	Flag	Start
Sunday 26 th July	Race 1	7	10:00
	Race 2	7	As soon as possible after Race 1

COURSES - Courses will be in vicinity of St Helens Fort.

SAILS & EQUIPMENT CHECKS - Spot checks to establish conformity with Class Rules may be made at the direction of the Race Committee before, during or after the Regatta.

SUPPORT BOATS - these are welcome but are governed by EWCC SI 18.1 unless required to rescue a boat in trouble.

SCORING SYSTEM - the Low Point Scoring System (RRS Appendix A) will apply. No discard.

RESULTS - results will be posted on the Notice Board at BHYC & BSC after racing.

PRIZES - prize giving to which all competitors are encouraged to attend will be held at BSC on Sunday 26th July at 16:00. The following prizes will be awarded:

1st Prize Overall - Solent Scow Championship Cup and a prize. **Scows 2nd & 3rd** - a prize each

1st Under 18 Helm - a prize.

SAFEGUARDING - In the event of any concerns relating to Safeguarding during this Regatta, please contact BSC's Welfare Officer (Gemma Wall) who can be contacted on 01983 872237 or email gemma@bembridgesailingclub.org

Rory Morrison
Rear Commodore (Sailing) BSC

Grainne Andrews
Rear Commodore (OnWater) BHYC

BEMBRIDGE VILLAGE REGATTA

Saturday 1st August 2026

NOTICE OF RACE

<i>HIGH & LOW WATER PORTSMOUTH (BST)</i>		
	HW	LW
Saturday 1 st August 2026	14:18 (4.5m)	19:28 (1.1m)

ORGANISATION

This event is part of the East Wight Combined Clubs' Series. The Organising Authority will be BSC with race management assistance provided by BHYC.

ELIGIBILITY & ENTRY

Helms must be members of an affiliated RYA Club. The Entry Requirements on page 2 of this programme and the Disclaimer of Liability in EWCC SI 21 apply. There is no Entry Fee.

REGISTRATION & BRIEFING

In addition to complying with the entry requirements, entrants in centreboard dinghies (incl multihulls) **must sign the Sign-On Sheet for their class at BSC, BHYC or SVYC at least 30 minutes before the scheduled race start time.** Failure to do so will result in the boat not being recognised as racing. PYs for entrants in Dinghy Class Races 3 & 5 and sail sizes for Race 4 **MUST** be entered on the appropriate Sign-On Sheet. There will not be a briefing.

RULES & SAILING INSTRUCTIONS

Races shall be governed by the World Sailing Racing Rules of Sailing 2025-2028, RYA Prescriptions, Class Rules, this Notice of Race and the Sailing Instructions. Races will be sailed under the East Wight Sailing Instructions, as varied by this Notice of Race. They can be downloaded from <https://www.ewcc.online/>

Class flags are as shown below. Races will be started in accordance with RRS 26. Rule 44.1 is changed so that the Two-turns Penalty is replaced by a One-turn Penalty.

PROGRAMME OF EVENTS

DINGHY CLASSES			
Race	Class	Flag	Sat 1 st Aug (start)
1	International Optimist & RS Tera	O	13:30
2	Solent Scow	7	13:35
3	Dinghy Slow Handicap (PY 1250 and over)	4	13:40
4	ILCA 4 (4.7)	V	13:45
5	RS Feva	F	13:50
6	Dinghy Fast Handicap (under PY 1250)	3	13:55

COURSES

Dinghy Classes - Races will start from a Committee Boat located in the area between the entrance to Bembridge Harbour and either Garland or Priory Bay depending on the wind direction.

SAILS & EQUIPMENT CHECKS

Spot checks to establish conformity with Class Rules may be made at the direction of the Race Committee before, during or after the Regatta.

SUPPORT BOATS

These are welcome but are governed by EWCC SI 18.1.

SCORING SYSTEM

The Low Point Scoring System (RRS Appendix A) will apply for combined prizes.

RESULTS

Results will be posted on the Notice Board at BSC (and e-mailed to BHYC & SVYC) as soon as possible after each day's racing.

PRIZES

Prize giving to which all competitors are encouraged to attend, will take place at BSC at **16:00** on **Saturday 1st August 2026**.

Race	Dinghy Classes	Saturday 1 st Aug 2026
1	Optimist & RS Tera	Queen Elizabeth II Cup
2	Solent Scow	Ocamore Cup
3	Dinghy Handicap (PY 1250 and over)	Vivian Lloyd Cup
4	International Laser 1 (4.7)	A prize
5	RS Feva	A prize
6	Dinghy Handicap (Under PY 1250)	Hodgekinson Trophy

SAFEGUARDING

In the event of any concerns relating to Safeguarding during this Regatta, please contact BSC's Welfare Officer (Gemma Wall) who can be contacted on 01983 872237 or email gemma@bembridgesailingclub.org

Laurence Blackburn
BSC Sailing Manager

Grainne Andrews
Rear Commodore (On Water) BHYC

INTERNATIONAL OPTIMIST CLASS & RS TERA OPEN REGATTA

Saturday 8th August 2026

NOTICE OF RACE

HIGH & LOW WATER PORTSMOUTH (BST)		
	HW	LW
Saturday 8 th August	07:34 (3.9m)	14:28 (1.8m)

4. ORGANISATION

This event is part of the EWCC Series. The Organising Authority will be SVYC.

SAILING INSTRUCTIONS

Races will be sailed under the East Wight Sailing Instruction (available from www.ewcc.online), as amended by this Notice of Race.

ELIGIBILITY

Helms must be members of an affiliated RYA Club. The Entry Requirements on page 2 of this programme, which includes agreement to be bound by the "Risk Statement" in EWCC SI 22 and the "Privacy Statement" in EWCC SI 23, apply. The event is open to Optimist boats, and RS Tera (both sail types) boats only.

ENTRY

Entries can be made via the SVYC Race Management website at www.svyccracedeck.org.uk. There is no entry fee. Entries will open around 1 week before the event.

BRIEFING

A briefing will be held at 09:30 at SVYC.

RULES

Races shall be governed by the World Sailing Racing Rules of Sailing 2025-2028. Protests must be notified to the Race Officer immediately after each race. Protest forms must be lodged with the Race Officer within 1 hour of the completion of racing. Rule 44.1 is changed so that the Two-turns Penalty is replaced by a One-turn Penalty. EWCC SI 8.5 (passing through the line after starting) will not apply. EWCC SIs 14.1 and 14.2 is changed such that the time limit for each race is 60 minutes (14.1), and the finishing window for all races is 20 minutes after the first boat (14.2).

Any Intentions to Protest should be notified to the Race Officer immediately after the race. Protest forms must be lodged with the Race Officer within 60 minutes of the last race.

PROGRAMME OF EVENTS

DATE	EVENT	FLAG	START
Saturday 8 th August	Briefing at SVYC		09:30
	Race 1	O	10:30
	Race 2	O	oc
	Race 3	O	oc
	Race 4	O	oc
	Prize Giving		ASAP after racing

All classes will race together. Racing will be handicapped using the Portsmouth Yardstick. No Warning signal will be made after 13:30.

COURSES

Racing will be from a Committee Boat. The position of the Committee Boat and the course to be used will be issued at the briefing.

SAFETY

When the race committee considers that a boat or a competitor is in difficulty, it may instruct the boat or competitor to accept outside help, retire and sail ashore. Support boats are welcome but should not interfere with the racing unless required to rescue a boat in trouble.

EQUIPMENT CHECKS

Spot checks to establish conformity with Class Rules may be made at the direction of the Race Committee before, during or after the Regatta.

A boat shall neither make radio transmissions while racing nor receive radio communications not available to all boats. This restriction also applies to mobile telephones and other similar devices.

SCORING

The Low Point Scoring System (RRS Appendix A) will apply. There will be one discard allowed if all 4 races per fleet are sailed, none if only 3 are sailed.

Results will be available online at www.svycraceck.org.uk as soon as possible after the completion of racing. Prizes will be awarded to the top 3 boats.

BOAT PARKING AND ACCESS

Boat parking is available in SVYC's Duver Dinghy Park. Launching ramps are located at the Duver Dinghy Park, and the SVYC concrete slipway.

SAFEGUARDING

In the event of any concerns relating to Safeguarding during this Regatta, please contact one of SVYC's Welfare Officers (Jon Curtis, Michele Reader, Suki Pountney or Gilly Meadows) who can be contacted though 01983 613268 or email training@svyc.org.uk.

Jimbo Mitchell - Rear Commodore (Sailing) SVYC

Jon Curtis - Sailing Director SVYC

SVYC / EWCC ILCA (LASER) GRAND PRIX

Sunday 9th August 2026

NOTICE OF RACE

<i>HIGH & LOW WATER PORTSMOUTH (BST)</i>		
	HW	LW
Sunday 9 th August	08:59 (4.0m)	14:28 (1.8m)

ORGANISATION

This event is part of the EWCC Series. The Organising Authority will be SVYC.

SAILING INSTRUCTIONS

Races will be sailed under the East Wight Sailing Instruction (available from www.ewcc.online), as amended by this Notice of Race. SI Addendum A will contain the course and other racing details, and will be published on the SVYC website no later than 24 hours before the first race.

ELIGIBILITY

Helms must be members of an affiliated RYA Club. The Entry Requirements on page 2 of this programme, which includes agreement to be bound by the "Risk Statement" in EWCC SI 22 and the "Privacy Statement" in EWCC SI 23, apply. The event is open to ILCA 4, 6 and 7 class boats only. Other ILCA rigs may be accepted at the discretion of the Race Committee but will not be eligible for any prizes.

ENTRY

Entries can be made via the SVYC website at www.svy.org.uk/event/svy-iow-ilca-grand-prix-5. All entrants must comply with the entry requirements. The entry fee will be £5.00 (reduced to £0 for members of EWCC clubs) and must be paid when entering. Entries will close at 09:30 on Sunday 9th August.

RULES

Races shall be governed by the World Sailing Racing Rules of Sailing 2025-2028. RYA National Prescriptions and ILCA Class Rules will apply. Rule 44.1 is changed so that the Two-turns Penalty is replaced by a One-turn Penalty. EWCC SI 4.2 is changed such that the Warning Signal will be made not less than 30 minutes after the removal of AP from ashore. EWCC SI 8.5 (passing through the line after starting) does not apply. EWCC SIs 14.1 and 14.2 is changed such that the time limit for each race is 60 minutes (14.1), and the finishing window for all races is 20 minutes after the first boat (14.2).

Any Intentions to Protest should be notified to the Race Officer immediately after the race. Protest forms must be lodged with the Race Officer within 60 minutes of the last race.

PROGRAMME OF EVENTS

DATE	EVENT	FLAG	START
Sunday 9 th August	Optional Briefing at SVYC		09:30
	Race 1	ILCA	11:00
	Race 2	ILCA	oc
	Race 3	ILCA	oc
	Race 4	ILCA	oc
	Prize Giving		ASAP after racing

All classes will race together. Racing will be handicapped using the Portsmouth Yardstick. No Warning signal will be made after 14:00.

EQUIPMENT CHECKS

Spot checks to establish conformity with Class Rules may be made at the direction of the Race Committee before, during or after the Regatta.

A boat shall neither make radio transmissions while racing nor receive radio communications not available to all boats. This restriction also applies to mobile telephones and other similar devices.

SCORING

The Low Point Scoring System (RRS Appendix A) will apply. There will be one discard allowed if all 4 races per fleet are sailed, none if only 3 are sailed.

Results will be available online at www.svyccracedeck.org.uk as soon as possible after the completion of racing. Prizes will be awarded to the leading helm and leading SVYC helm in each rig, and the overall.

BOAT PARKING AND ACCESS

Boat parking is available in SVYC's Duver Dinghy Park. Launching ramps are located at the Duver Dinghy Park, and the SVYC concrete slipway.

SAFEGUARDING

In the event of any concerns relating to Safeguarding during this Regatta, please contact one of SVYC's Welfare Officers (Jon Curtis, Michele Reader, Suki Pountney or Gilly Meadows) who can be contacted though 01983 613268 or email training@svyc.org.uk.

Jimbo Mitchell - Rear Commodore (Sailing) SVYC

Jon Curtis - Sailing Director SVYC

BEMBRIDGE SAILING CLUB REGATTA

Friday 14th and Saturday 15th August 2026

NOTICE OF RACE

<i>HIGH & LOW WATER PORTSMOUTH (BST)</i>		
Date	LW	HW
Friday 14 th August	06:23 (0.5m)	13:28 (4.8m)
Saturday 15 th August	07:04 (0.5m)	14:17 (4.8m)

ORGANISATION

This event is part of the East Wight Combined Clubs' Series. The Organising Authority will be BSC with race management assistance provided by SVYC and BHYC.

ELIGIBILITY & ENTRY

Helms must be members of an affiliated RYA Club. The Entry Requirements on page 2 of this programme and the Disclaimer of Liability in EWCC SI 21 apply. There is no Entry Fee.

REGISTRATION & BRIEFING

In addition to complying with the entry requirements, entrants in centreboard dinghies (incl multihulls) **must sign the Sign-On Sheet for their class at BSC, BHYC or SVYC at least 30 minutes before the scheduled race start time.** Failure to do so will result in the boat not being recognised as racing. PYs for entrants in Dinghy Class Races 3 & 5 and sail sizes for Race 4 **MUST** be entered on the appropriate Sign-On Sheet. There will not be a briefing. Entries in Race 1 (Handicap Cruisers) will require to have a YTC handicap certificate.

RULES & SAILING INSTRUCTIONS

Races shall be governed by the World Sailing Racing Rules of Sailing 2021-2024, RYA Prescriptions, Class Rules, this Notice of Race and the Sailing Instructions. Races will be sailed under the East Wight Sailing Instructions, as varied by this Notice of Race. They can be downloaded from <https://www.ewcc.online/>

Class flags are as shown below. Races will be started in accordance with RRS 26; however, for the *Keelboat Classes* there will be a 5 minute gap between the start of each Class and the warning for the next one - this modifies RRS 26. Rule 44.1 is changed so that the Two-turns Penalty is replaced by a One-turn Penalty.

PROGRAMME OF EVENTS

KEELBOAT CLASSES				
Race	Class	Flag	Fri 14 th Aug & Sat 15 th Aug (start)	
1	Handicap Cruiser	2	10:30	
2	Redwing	R	10:40	
3	Seaview Mermaid	9	10:50	
4	Bembridge One Design	NN8	11:00	
5	Victory Class	Z	11:10	
6	National Squib & International Flying Fifteen	NN9	11:20	
DINGHY CLASSES				
Race	Class	Flag	Fri 14 th Aug (start)	Sat 15 th Aug (start)
1	International Optimist & RS Tera	O	13:00	14:00
2	Solent Scow	7	13:05	14:05
3	Dinghy Slow Handicap (PY 1250 and	4	13:10	14:10

	over)			
4	ILCA 4 (4.7)	V	13:15	14:15
5	RS Feva	F	13:20	14:20
6	Dinghy Fast Handicap (under PY 1250)	3	13:25	14:25

COURSES

Keelboat Classes - races will start from a Committee Boat Starting Line positioned off St Helens Fort.

Dinghy Classes - Races will start from a Committee Boat located in the area between the entrance to Bembridge Harbour and either Garland or Priory Bay depending on the wind direction.

SAILS & EQUIPMENT CHECKS - Spot checks to establish conformity with Class Rules may be made at the direction of the Race Committee before, during or after the Regatta.

SUPPORT BOATS - These are welcome but are governed by EWCC SI 18.1.

SCORING SYSTEM - The Low Point Scoring System (RRS Appendix A) will apply for combined prizes.

RESULTS - Results will be posted on the Notice Board at BSC (and e-mailed to BHYC & SVYC) as soon as possible after each day's racing.

PRIZES - Prize giving (for dinghy & keelboat classes), to which all competitors are encouraged to attend, will take place at BSC at **17:30** on **Saturday 15th August**.

SAFEGUARDING

In the event of any concerns relating to Safeguarding during this Regatta, please contact BSC's Welfare Officer (Gemma Wall) who can be contacted on 01983 872237 or email gemma@bembridgesailingclub.org

Race	KEELBOAT CLASSES	Friday	Saturday
1	Handicap Cruisers	A prize	A prize
2	Redwing	Percy Browne Cup	Evelyn Moreton Cup
3	Sea View Mermaid	A prize	A prize
4	Bembridge One Design	Chetwynd Trophy	QE II Coronation Cup
5	National Squib & International Flying Fifteen	A prize	A prize
Race	DINGHY CLASSES	Friday	Saturday
1	Optimist & RS Tera	A prize	A prize & Peel Cup (<i>1st BSC Oppy both races</i>)
2	Solent Scow	Scow Salver	Bennett Cup
3	Dinghy Handicap (PY 1250 and over)	A prize	A prize
4	International Laser 1 (4.7)	A prize	A prize & Astrop Cup (<i>1st BSC Laser both races</i>)
5	RS Feva	A prize	A prize
6	Dinghy Handicap (Under PY 1250)	A prize	A prize

Rory Morrison
Rear Commodore (Sailing) BSC

Laurence Blackburn
Sailing Manager BSC

SEA VIEW YACHT CLUB REGATTA

Sunday 16th and Monday 17th August

NOTICE OF RACE

<i>HIGH & LOW WATER PORTSMOUTH (BST)</i>		
	HW	LW
Sunday 16 th August	15:07 (4.7m)	07:44 (0.6m)
Monday 17 th August	15:47 (4.8m)	08:22 (0.9m)

ORGANISATION

This event is part of the EWCC Series. The Organising Authority will be SVYC.

SAILING INSTRUCTIONS

Races will be sailed under the East Wight Sailing Instruction (available from www.ewcc.online), as amended by this Notice of Race.

ELIGIBILITY

Helms must be members of an affiliated RYA Club. The Entry Requirements on page 2 of this programme, which includes agreement to be bound by the "Risk Statement" in EWCC SI 22 and the "Privacy Statement" in EWCC SI 23, apply.

ENTRY

Entries (except the Seaview Mermaid class) must be made online via the SVYC race management platform at www.svyccracedeck.org.uk no less than 30 minutes before the race start time. Entries for the Seaview Mermaid Class must be made on the SVYC website no later than 18:00 on Friday 9th August. Visiting boats may sign on by VHF radio to 'Seaview Deck' no later than 20 minutes before their start. There is no entry fee.

RULES

Races shall be governed by the World Sailing Racing Rules of Sailing 2025-2028. RYA National Prescriptions and the relevant Class Rules will apply. In the event of a conflict between the NoR and Sis, this NoR shall take precedence.

Rule 44.1 is changed so that the Two-turns Penalty is replaced by a One-turn Penalty, except in the SVOD Class for a breach of RRS 18.3 (changing tack at a windward mark) when a Two-Turns penalty applies. EWCC SI 8.5 (passing through the line after starting) does not apply.

Competitors are not required to immediately inform the Race Committee of an intention to protest after finishing (changing SI 15.1). Protest forms must be lodged with the Race Committee within 60 minutes of the completion of the race.

SI 14.1 (Time Limits) is changed such that the time limit for all races is 90 minutes, except for Handicap Cruisers where it will be 3 hours. SI 14.2 is amended such that the finishing window is changed to 40 minutes after the first boat. SI 14.3 is amended such that, additionally, under extraordinary circumstances, the result of the race for that class may be determined from a previously recorded time for all boats at a rounding mark or line crossing.

COURSES

The course to be sailed will be displayed no later than four minutes prior to the Warning Signal. In addition to SI 8.1, additional marks are specified for use by the Race Committee as shown in Addendum A. Courses for the Handicap Cruiser Class and J/70 Class may not be displayed, in which case the course read on VHF immediately after the Warning Signal shall be treated as correct. All keelboat classes must pass to seaward of the following marks and obstructions when racing: mark 17, mark 13, mark 12, mark 14, St Helens Fort.

PROGRAMME OF EVENTS

RACE	CLASS	FLAG	START (both days)
1	SVOD (cadets)	W	09:30
2	Handicap Cruiser	2	10:20
3	Seaview Mermaid	9	10:30
4	National Squib & International Flying Fifteen	NN9	10:40
5	Portsmouth Victory Class	Z	10:50
6	Cadet Squad (Optimists & Teras)	O	11:00
7	Drascombe Lugger	6	11:10
8	International ILCA Laser Handicap	ILCA	11:20
9	Seaview Mermaid	9	12:00
10	Handicap Dinghy (over PY 1240)	4	12:10
11	Bembridge Redwing	R	12:20
12	Bembridge One-Design	NN8	12:30
21	J/70 Class	M	13:30 – Sunday Only
13	Cadet Squad (Optimists & Teras)	O	14:10
14	Handicap Dinghy (under PY 1240)	3	14:20
15	Seaview Mermaids Handicap (Modern & Classic)	9	14:30
16	National Squib & International Flying Fifteen	NN9	14:40
17	Portsmouth Victory Class	Z	14:50
18	Seaview Mermaid	9	16:10
19	SVOD Victory fleet	D	16:20
20	SVOD Amber fleet	W	16:30

Races may start from either the SVYC Race Deck or a Committee Boat.

SVYC FIXED STARTING / FINISHING LINES

Orange Starting Line is an extension of a line formed by bringing the SVYC flagstaff in line with an orange and white vertical marker board on the wall of the SVYC building. The Yellow Post is on an extension of this line. When starting, boats (except Cruisers) must pass between two yellow buoys marking the outer and inner limits of the line, for Cruisers the inner and outer limit marks will be inflatables placed on the seaward side of the Yellow Post. When code flag E is displayed at the warning signal the inner limit mark does not apply. This line is indicated by an Orange board at the start of the course. If no starting line board is displayed, the Orange Starting Line will be used.

Green



Starting Line is a line formed between the SVYC flagstaff and a green-topped outer limit Inflatable mark. There will also be an inner limit inflatable mark laid approximately on the line unless Flag E is displayed at the same time as course publication, when there will not be an inner limit mark. This line is indicated by a Green board at the start of the course.

Club Finishing Line is an extension of a line formed by bringing the SVYC flagstaff in line with an orange and white vertical marker board on the wall of the SVYC building. The Yellow Post is on an extension of this line. When courseboard 'Black L' is displayed: all Keelboat classes must pass between the two yellow buoys marking the outer and inner limits of the line; all Dinghy classes must pass between the SVYC flagstaff and the yellow outer distance mark. When courseboard 'Blue L' is displayed, or for all Cruiser Class races, all boats must finish between the inflatable inner and outer limit marks which will be placed on the seaward side of the yellow post.

When course board 'Black 10' is displayed: number 10 buoy becomes the outer limit mark for the finish.

For all fixed Starting / Finishing lines: If a Limit mark is lying beyond the Finishing line, boats when starting / finishing shall leave on the required side both the Limit mark and the point on the finishing line nearest to the Limit mark.

Shorten Course at a Line Crossing: A race may be shortened from ashore when the Club Finishing line is a specified mark of the course. Shortened course will be signalled by displaying Flag S from ashore with two sound signals before the leading boat has crossed the line.

EQUIPMENT CHECKS

Spot checks to establish conformity with Class Rules may be made at the direction of the Race Committee before, during or after the Regatta. All competitors in centreboard dinghies, small multihulls, and foiling boats, and those required to do so under class rules, shall always wear adequate personal flotation devices while afloat except briefly while changing or adjusting clothing or personal equipment.

A boat shall neither make radio transmissions while racing nor receive radio communications not available to all boats. This restriction also applies to mobile telephones and other similar devices.

SCORING

The Low Point Scoring System (RRS Appendix A) will apply for combined prizes.

Results will be available online at www.svycracedeck.org.uk as soon as possible after the completion of each race.

Prizes for first, second and third in each race, depending on the number of entrants, will be presented at a prizegiving to be held at the SVYC at **18:30** on Monday 17th August. All competitors are encouraged to attend. The trophies for each race (where applicable) can be found in Addendum B.

BOAT PARKING AND ACCESS

Boat parking is available in SVYC's Duver Dinghy Park. Launching ramps are located at the Duver Dinghy Park, and the SVYC concrete slipway. A launch service to the SVYC visitor moorings will be available throughout the regatta.

SAFEGUARDING

In the event of any concerns relating to Safeguarding during this Regatta, please contact one of SVYC's Welfare Officers (Jon Curtis, Michele Reader, Suki Pountney or Gilly Meadows) who can be contacted though 01983 613268 or email training@svyc.org.uk.

Jimbo Mitchell - Rear Commodore (Sailing) SVYC

Jon Curtis - Sailing Director SVYC

ADDENDUM A – ADDITIONAL MARKS

DESIGNATION	NAME	SHAPE & COLOUR
≈	Seaview Sailing Trust	Dumpy Inflatable
12	Quay Rocks	Red Top Hat Can
13	Bunch	Red Top Hat Can
14	Old Fort	Red Top Hat Can
17	Big Ben Rock	Red Top Hat Can
22	Twenty Two	Tall Inflatable

The J/70 Class only may also use marks designated on the Solent Racing Cruising Association website (<https://www.scra.org.uk/solent-marks/solent-marks2>), as well as both the Ryde Sands Post (west) and Ryde Sands Post (east).

ADDENDUM B – TABLE OF TROPHIES

	CLASS		SUNDAY	MONDAY
1	SVOD (Cadets)		Cade Cups (boys/girls)	Dobbs Tankard
2	Handicap Cruiser		Handicap Cruiser Cup	Ian Gilchrist Salver
3	Seaview Mermaid		Bufs Cup	John Sandiford Haigh Memorial Cup
4	National Squib & International Flying Fifteen		A prize	A prize
5	Victory Class		A prize	A prize
6	Cadet Squad (Optimists & Teras)		Simonds Cup (Leading Optimist combined both days)	
7	Drascombe Lugger		A prize	A prize
8	International ILCA Laser Handicap		Lakin Cup	Reynolds Cup
9	Seaview Mermaid		Bruce Donald Cup	Donald Bowl
10	Handicap Dinghy (PY>1240)		Weir Trophy	Jim St Clair-Ford Tankard
11	Bembridge Redwing		Bizarre Bowl	Baly Beach Bell
12	Bembridge One Design		Bullin Cup	Bullin Cup
13	Cadet Squad (Optimists & Teras)		A prize	A prize
14	Handicap Dinghy (PY<1240)		Almond Cup	Hunter Cup
15	Seaview Mermaid	Modern	John Scott-Hughes Bowl	Somers Tankard
		Classic	Edwards Tankard	A prize
16	National Squib & International Flying Fifteen		A prize	A prize
17	Victory Class		A prize	A prize
18	Seaview Mermaid		Few Brown Salver	Pam Donald Memorial Trophy
19	SVOD Victory Fleet		Gordon Walker Salver	Victory Cup
20	SVOD Amber Fleet		Sir Edward Blount Cup	Sir Edward Blount Cup
21	J/70 Class		A prize	N/a

In addition, the following series trophies will be awarded:

Laser Pico	David Farquhar Cup (1 st in Race 10 - Sunday)
	Brandt Cup (1 st in Race 10 - Monday)
	Casey Cup (2 race series across Race 10 Sunday & Monday)
National Squib	The Squib Model (4 race series with 1 discard)
	Sallemanda Trophy (1 st SVYC boat for 6 race series with 1 discard over 4 days of BSC and SVYC regattas)
RS Feva	Bottomley Cup (2 race series across Race 10 Sunday & Monday)

J/70 REGATTA

Saturday 15th & Sunday 16th August 2026

NOTICE OF RACE

<i>HIGH & LOW WATER PORTSMOUTH (BST)</i>		
Date	HW	LW
Saturday 15 th August	07:04 (0.5m)	14:17 (4.8m)
Sunday 16 th August	15:07 (4.7m)	07:44 (0.6m)

ORGANISATION

This event is part of the East Wight Combined Clubs' Series. The Organising Authority will be BSC.

ELIGIBILITY AND ENTRY

Helms must be members of an affiliated RYA Club. The Entry Requirements are set out on page 2 of this programme, which includes agreement to be bound by the "Risk Statement" in EWCC SI 22 apply. Entry Forms are available from BSC. There is no fee. There will be an optional race (at 14:35) as part of BSC's Regatta on Friday 14th August.

BRIEFING

There will be a briefing at BSC at 08:30 on Saturday 15th August & Sunday 16th August.

RULES & SAILING INSTRUCTIONS

Races shall be governed by the World Sailing Racing Rules of Sailing 2025-2028, RYA Prescriptions, Class Rules, this Notice of Race and the Sailing Instructions. Races will be sailed under the East Wight Sailing Instructions, as varied by this Notice of Race. They can be downloaded from <https://www.ewcc.online>

The Class flag will be M. Rule 44.1 is changed so that the Two-turns Penalty is replaced by a One-turn Penalty.

PROGRAMME OF EVENTS (may vary depending on the number of boats entered)

Date	Races	Start	Type	Notes
Saturday 15 th August	Races 1, 2, 3, 4 & 5	10:00 & o/c	Short	Lunch between 13:50 and 14:20
	Race 6	14:35	Long	As part of the BSC Regatta
Sunday 16 th August	Races 7, 8, 9, 10 & 11	10:00	Short	Race 11 to finish at SVYC
	Race 12	13:30	Long	Start at SVYC and finish at Royal London race mark Cowes

COURSES – Except for Races 11 & 12, races will be run to the east of St Helens Fort. Except for Race 12, courses will be as signalled on the stern of the Committee Boat and announced over VHF radio. The Course for Race 12 will be announced over VHF radio only.

SAIL COMBINATIONS – the following sail combinations will be applied.

WIND (Knots)	Main	Jib	Spinnaker	Notes
0-5	<i>Full</i>	Yes	Yes	
5-10	<i>Full</i>	Yes	Yes	
10-15	<i>Full</i>	Yes	<i>RO Discretion</i>	
15-20	<i>One Reef</i>	<i>Old</i>	No	
20+	No	No	No	<i>Sailing cancelled at RO's discretion</i>

RADIO COMMUNICATIONS - as per EWCC SI 20.1. A VHF radio shall be carried and on listening watch so that safety & race management information may be passed on Channel **77**.

SUPPORT BOATS - are welcome but governed by EWCC SI 18.1 unless required for rescue purposes.

SCORING SYSTEM - the Low Point Scoring System (RRS Appendix A) will apply. There will be two discards allowed if more than 9 races are sailed; one if between 5 and 8 races are sailed; none if fewer than 5 are sailed.

MOORING - swinging moorings and related launch services will be available at Under Tyne & Seaview and will be based on entrant preference linked to their overnight accommodation. Arrangements for this will be published via the BSC website.

RESULTS - results will be announced during Prize Giving and included in the Regatta Report.

PRIZES - prize giving will take place on completion of racing on Sunday 16th August at Shepard's Wharf, Cowes

SOCIAL PROGRAMME - will be published separately via the BSC website/J/70 WhatsApp.

SAFEGUARDING

In the event of any concerns relating to Safeguarding during this Regatta, please contact BSC's Welfare Officer (Gemma Wall) who can be contacted on 01983 872237 or email gemma@bembridgesailingclub.org

Rory Morrison
Rear Commodore (Sailing) BSC

Andrew Eddy
BSC Co-Ordinator

BHYC ANNUAL REGATTA 2026 - NOTICE OF RACE

(incorporating the Mermaid Gin Regatta)

HIGH & LOW WATER PORTSMOUTH (BST)		
	HW	LW
Saturday 29 th August	13:14 (4.7m)	18.30 (0.9m)
Sunday 30 th August	14.46 (4.7m)	19.03 (0.8m)

ORGANISATION

This event is a 2 day regatta, part of the East Wight Combined Clubs' Series with 2 races per day planned for dinghies. The Organising Authority will be BHYC with race management assistance provided by BSC for the Keelboat Class events.

ELIGIBILITY & ENTRY

Helms must be members of an affiliated RYA Club. The Entry Requirements on page 2 of this programme, which includes agreement to be bound by the "Risk Statement" in EWCC SI 22 and the "Privacy Statement" in EWCC SI 23 apply. There is no Entry Fee.

REGISTRATION & BRIEFING

Online entry prior to the event is encouraged for all dinghies that comply with the EWCC entry requirements. If Online entry is not possible, then entrants in centreboard dinghies must sign the Sign-On Sheet for their class at BHYC, BSC or SVYC at least 30 minutes before the scheduled race start time. Failure to do so may result in the boat not being recognised as racing. PYs should be entered on the appropriate Sign-On Sheet. There will not be a briefing.

RULES & SAILING INSTRUCTIONS

Races shall be governed by the World Sailing Racing Rules of Sailing 2025-2028, RYA Prescriptions, Class Rules, this Notice of Race and the Sailing Instructions. Races will be sailed under the East Wight Sailing Instructions, as varied by this Notice of Race. They can be downloaded from <https://www.ewcc.online>

Class flags are as shown below. Races will be started in accordance with RRS 26; however, there will be a 5 minute gap between the start of each Keelboat Class and the warning for the next one - this modifies RRS 26. Rule 44.1 is changed so that the Two-turns Penalty is replaced by a One-turn Penalty.

DINGHY CLASSES				
Start	Class	Flag	Sat Race 1 (Race 2 to follow asap)	Sun Race 3 (Race 4 to follow asap)
1	Dinghy Fast Handicap (under PY 1240)	3	12:00	13:00
2	Cadet Classes Group Start: Tera ILCA 4	Tera Flag Laser Flag	12:05	13:05
3	Dinghy Slow Handicap (PY 1240 and over), includes Swans	4 Swan Flag	12:10	13:10
4	Solent Scow	7	12:15	13:15
KEELBOAT CLASSES				
Start	Class	Flag	Sat (29 TH) & Sun (30 th) (Start)	
1	Bembridge Redwing	R	12:00	
2	Bembridge One Design	NN8	12:10	
4	Seaview Mermaid	9	12:20	
3	International Flying Fifteen	NN9	12:30	

COURSES

Keelboat Classes - Races will start from the BSC Committee Boat Starting Line positioned off St Helens Fort.

Dinghy Classes - Races will start from a Committee Boat located in the area between the entrance to Bembridge Harbour and either Garland or Priory Bay depending on the wind direction.

SAILS AND EQUIPMENT CHECKS - Spot checks to establish conformity with Class Rules may be made at the direction of the Race Committee before, during or after the Regatta.

SUPPORT BOATS - These are welcome but are governed by EWCC SI 18.1 unless required to rescue a boat in trouble.

SCORING SYSTEM

The Low Point Scoring System (RRS Appendix A) will apply for combined prizes. When 4 or more races are held, a boat's series score shall be the total of her race scores excluding her worst score. A minimum of 1 race is required to give an overall result.

RESULTS

Results will be posted on the Notice Board at BHYC and online at www.BHYC.ORG.UK as soon as possible after each day's racing.

PRIZES

Prize giving will be held at BHYC at 17.00 hours on Sunday 30th August. All competitors are encouraged to attend.

INSHORE CLASSES

	Class	Prizes
1	Dinghy Fast Handicap (under PY 1240)	Ted Eyre-Williams Cup to the leader on Saturday. Whitehead Cup to the overall winner. A prize for any class that has 5 or more entrants.
2	Cadet Classes	Mander Cup to the leader on Saturday H Dyer Cup to the overall winner A prize for any class that has 5 or more entrants.
3	Dinghy Slow Handicap (PY 1240 and over)	AA Coombs Designer Cup to the leading Swan on Saturday. Seawych Jubilee Cup to the leading Slow Handicap boat on Saturday. Vivian Lloyd Regatta Cup to the overall Swan winner. Hilson Cup to the overall Slow Handicap winner. A prize for any class that has 5 or more entrants.
4	Solent Scow Wooden Scow	BHYC Scow Regatta Cup to the leader on Saturday. Commodore's Scow Cup to the overall winner. Gabbani Woody Cup to the overall best wooden Scow.

KEELBOAT CLASSES

	Class	Prizes
1	Bembridge Redwing	Loch-Nell Trophy. A prize to the overall winner.
2	Bembridge One Design	Selwyn Cup for Saturday. Hector Humphray Cup for Sunday. A prize to the overall winner.
3	Seaview Mermaid	A prize to the overall winner.
4	International Flying Fifteen	A prize to the overall winner.

SAFEGUARDING

In the event of any concerns relating to Safeguarding during this Regatta, please contact BHYC's Welfare Officer (Sarah Noyes) who can be contacted at welfare@bhyc.org.uk.

Grainne Andrews
Rear Commodore (Onwater) BHYC

Rory Morrison
Rear Commodore (Sailing)

ROYAL VICTORIA YACHT CLUB MERRYDOWN REGATTA

Sunday 30th August

NOTICE OF RACE

<i>HIGH & LOW WATER PORTSMOUTH (BST)</i>	<i>HW</i>	<i>LW</i>
Sunday 30 th August	13:33 (4.7m)	18:56 (0.9m)

ORGANISATION

This event is part of the EWCC Regatta Series. The organising authority will be RVYC.

ELIGIBILITY AND ENTRY

Entry is open to Cruisers (multihull and monohull), which will be dual scored using MOCRA and YTC ratings and handicaps, Dayboats and Dinghies. Helms must be members of RYA affiliated clubs.

RULES

Racing will be governed by the rules defined in the 2025-2028 World Sailing Racing Rules of Sailing (RRS), RYA Prescriptions, Class Rules, RVYC Race Chart 2026 and this Notice of Race (except where modified by the RVYC Merrydown 2026 SIs) and the RVYC Merrydown Regatta 2026 Sailing Instructions which replace the EWCC Regatta Series 2026 Sailing Instructions. In a case of conflict, the RVYC Merrydown 2026 SIs will apply. The RVYC Merrydown 2026 SIs will be available by 1st August 2026 from the RVYC website or office.

PROGRAMME OF EVENTS

Sunday 10:00 Briefing (on the lawn near the club pontoon)
11:30 First race start not before

There will be one long race for Cruiser & MOCRA classes and a maximum of three short races for other classes including Scows. It is intended that the final race will be an all-classes start (excluding MOCRA & Cruiser), which will race for the Merrydown Trophy. The details of classes will be set out in the RVYC Merrydown 2026 SIs.

COURSES

Racing (except for Scows which will race in Wootton Creek) will be started and finished at the RVYC Race Box to the west of Wootton Creek or from a Committee Boat. Courses will be in the Eastern Solent in accordance with the RVYC Race Chart 2026.

RESULTS AND PRIZES

Results will be published on the RVYC website and on the Regatta Notice Board as soon as possible. Prizegiving will be held as soon as possible after the results have been finalised on Sunday 30th August.

INSURANCE

Each participating boat shall be insured with valid third-party liability insurance with a minimum cover of £5,000,000.

SAFEGUARDING

In the event of any concerns relating to Safeguarding during this Regatta, please contact RVYC's Welfare Officer (James Humphries) who can be contacted through the Club e-mail: office@rvyc.org.uk or on the Club landline number 01983 882325.

For further information, please check <https://www.rvyc.org.uk/open-events/regattas> or contact the RVYC on 01983 882325 or email office@rvyc.org.uk

Jane Barrett Bellingham - Commodore RVYC

EWCC SAILING INSTRUCTIONS 2026

1 RULES

- 1.1 Except where amended by these Sailing Instructions (SIs), all races will be governed by the rules as defined in the current Racing Rules of Sailing 2025-2028.
- 1.2 When sailing in the deep water channel boats are required to give way to large vessels (commercial & naval) proceeding either to and from the ports of Portsmouth and Southampton or the anchorage at St Helen's Roads.
- 1.3 Each boat sailing in a Class or under the Handicap for that Class shall comply with its Class Rules, which will take precedence. All boats must carry the minimum buoyancy required under their Class Rules (or as built, in the absence of any specific Class Rule).
- 1.4 For all competitors an adequate personal flotation device shall be carried on board, and these shall be worn at all times while afloat, except briefly while changing or adjusting clothing or personal equipment, if
 - (i) they are competing in centreboard dinghies, or small multihulls or
 - (ii) they are under 18 in any class, or
 - (iii) class rules require it, or
 - (iv) flag Y is displayed ashore or from the committee boat;This changes RRS 40.
An adequate flotation device is a life-jacket or buoyancy aid to a minimum of 50 Newtons EN393/ISO12402-5, or 100 Newtons for weak swimmers or non-swimmers.
- 1.5 Racing rules will be changed as follow.
 - Part 4 pre-amble and RRS 40 in SI 1.4 (wearing of personal buoyancy)
 - Definition of AP (SI 4.2 displayed ashore - one hour's notice after removal)
 - RRS 27.1 in SI 8.1 (course to be displayed prior to the Preparatory signal)
 - RRS 31 & 44.1 in SI 13.1 (penalties)
 - RRS 33 in SI 11.1 & 11.2 (course changes)
 - RRS 35 in SI 14 (time limit for handicap races)
 - RRS 37 in SI 20.2 (Flag D in lieu of Flag V)
 - RRS 61.1 (protest notification for boats under 6 metres)
 - RRS 62.1 in SI 10.5 (notification of OCS)
 - RRS 63.7(b) (re-opening hearing on last day of a regatta)
- 1.6 In races for Handicap Cruisers the handicap will be as set out in the Entry Requirements on Page 2. In races for handicap dinghies, the Portsmouth Yardstick of the boat, as amended by the organising Club(s) will be used.

2 NOTICES TO COMPETITORS

- 2.1 Notices to competitors will be posted on the official notice board located at the organising Club(s). Additionally they will be posted on-line (the organising Club's website and/or social media).

3 CHANGES TO SAILING INSTRUCTIONS

- 3.1 Changes to the SIs made prior to 3 hours before the scheduled starting time of a race will be posted in accordance with SI 2.1 except that any change in the schedule of the races will be posted by 18:00 on the day before it will take place. Changes made less than 3 hours before the scheduled starting time of a race started from a Committee Boat will be written on a board displayed on the Committee Boat and indicated by displaying flag 2nd Substitute with two sounds.

4 SIGNALS MADE FROM ASHORE

- 4.1. Signals made from ashore will be flown from the flagstaff of the organising Club(s).
- 4.2. Code Flag AP flown from the flagstaff of the organizing Club(s) with two sound signals means the race is postponed. The Warning Signal for any subsequent Committee Boat

starts will be made not less than one hour after the AP is lowered with one sound signal (This changes Flag AP).

5 **SCHEDULE OF RACES**

5.1 The schedule of races is as given in the Notice of Race.

6 **CLASS FLAGS**

6.1 Class Flags will be as in the Notice of Race.

7 **RACING AREA**

7.1 The racing area will be in the Eastern Solent (see EWCC chart on the cover of this Programme or RVYC chart).

8 **THE COURSE**

8.1 The Course to be sailed will be displayed by letters, numbers or symbols listed with these SIs no later than the Preparatory Signal. This changes RRS 27.1

8.2 A RED or ORANGE Background to the letter, number or symbol indicates that the buoy shall be rounded to PORT. A GREEN background to the letter, number or symbol indicates that the buoy shall be rounded to STARBOARD. If a board and markers is used then all marks shall be rounded to STARBOARD unless UNDERLINED when they shall be rounded to PORT.

8.3 If two DIAMONDS are displayed on the Course Board, the sequence before the diamonds shall be sailed twice before continuing to the marks displayed after the diamonds. If three DIAMONDS are displayed on the Course Board, the sequence before the diamonds shall be sailed thrice before continuing to the marks displayed after the diamonds.

8.4 When a BLACK AND ORANGE CHEQUERED board is displayed in the Course, the mark(s) preceding this board will be rounded before rounding the marks displayed after the chequered board for the number of times indicated.

8.5 **For all races starting and/or finishing from a Committee Vessel.** Whilst the Orange or Blue or S flag is displayed, and except during their own class's starting sequence or when finishing, no boat shall pass in either direction through the committee vessel start line after rounding the first mark of their course or the committee vessel finish line.

8.6 The above rule does not apply to a finish line if course board £ is displayed as the last mark of the course or round.

8.7 **SPECIAL COURSES**

8.7.1 **Special Course 1** will be a windward/leeward course with a wing mark as described in Appendix 1.1. This will be signalled from the committee boat by displaying a course board with a 1 on it followed by the marks to be rounded in accordance with Appendix 2.

8.7.2 **Special Courses 2, 3 & 4** will be a trapezoid course as shown in Appendix 1.2. These will be signalled from the committee boat by displaying a course board with a 2, 3 or 4 on it. Inflatable marks will be used.

8.7.3. **Special Course 5** will be a windward/leeward course with a leeward finish as shown in Appendix 1.3. This will be signalled from the committee boat by displaying a course board with a 5 on it. The number of rounds to be sailed will be indicated by the number of diamonds displayed on a course board. If a windward spreader, a leeward spreader and/or a leeward gate is to be used, this will be signalled from the Committee boat in accordance with Appendix 2.

8.7.4. **Special Course 6** will be a windward/leeward course with a windward finish as shown in Appendix 1.3. This will be signalled from the committee boat by displaying a course board with a 6 on it. The number of rounds to be sailed will be indicated by the number of diamonds displayed on a course board. If a windward spreader, a leeward spreader and/or a leeward gate is to be used, this will be signalled from the Committee boat in accordance with Appendix 2.

8.7.5 For Special Courses 1, 5 & 6, the start and finish lines may be placed at any point between the windward and leeward marks shown in the diagrams in Appendices 1.1 & 1.3.

9 **MARKS**

9.1 Marks of the Course will be either inflatable moveable buoys, or navigation buoys or marks permanently laid as shown on the chart of the area reproduced on the cover of this programme and listed in Appendix 2. The Finishing Mark is described in SI 12.

10 **THE START**

10.1 Races will be started in accordance with RRS 26 (unless varied in the Notice of Race).

10.2 The Orange Flag may be displayed (with one sound signal) 5 minutes before the warning signal of the first race. It will be removed when all starters have crossed the starting line.-

10.3 Boats whose Warning Signal has not been made shall keep clear of the starting area.

10.4. A boat shall not start later than 4 minutes after her starting signal for a 5 minute starting sequence or 9 minutes after her starting signal for a 10 minute starting sequence.

10.5 If any part of a boat's hull is on the course side of the starting line at her starting signal and she is identified, the race committee will attempt to hail her sail number. Failure to hail her number, failure of her to hear such a hail, or the order in which boats are hailed will not be grounds for a redress for request. This changes RRS 61.1(a).

COMMITTEE BOAT STARTING LINE

10.6 Unless otherwise indicated in the Notice of Race, a Committee Boat Starting Line will be used.

10.7 The Committee Boat Starting Line will be between a staff displaying an Orange Flag on the Committee Boat at the starboard end, and the Course side of the starting mark at the port end.

10.8 A RIB or inflatable buoy may be attached to the Committee Boat.

10.9 The Committee Boat may hold position by using engines.

11 **CHANGES OF COURSE AFTER THE START**

11.1 A change of course after the start will be signaled before the leading boat has begun the leg, although the new mark may not then be in position. Code Flag C will be flown and either the new Course to be sailed from the mark where it is displayed or the approximate compass bearing to the new mark (or a red rectangle for a change to port or a green triangle for a change to starboard) and a + or – sign to indicate the lengthening or shortening of a leg. This changes RRS 33. A periodic Sound Signal will be made. Any mark to be rounded after rounding the new mark may be relocated to maintain the original Course configuration without further signals. When in a subsequent change of Course a new mark is replaced, it will be replaced with the original mark.

11.2 Minor mark moves (up to approximately 100 metres) may be made without signalling the change. This changes RRS 33.

12 **FINISH**

12.1 Unless otherwise indicated in the Course instructions, the Finishing Line will be between the mast or staff displaying a BLUE flag on the Finishing Committee Boat and the Course side of the Finishing Mark. Except in the case of Special Courses 1, 2 & 3 the Finishing Mark is the last mark of the Course shown, or for a shortened Course the adjacent rounding mark. When the last mark of a course or round is displayed using Course Board £, boats must pass through the finishing line at the end of each round. The S Flag will be substituted for the BLUE Flag if the Course is shortened.

12.2 The Finishing Committee Boat may be held position by using engines.

13 **PENALTY SYSTEM**

13.1 Unless otherwise indicated in the Notice of Race or disallowed under Class Rules, RRS 31 (touching a mark - a one-turn penalty to include one tack & one gybe) and 44.1 (breaking a Part 2 Rule - a two-turn penalty to include two tacks & two gybes) apply.

14 **TIME LIMIT**

- 14.1 Unless modified in the NoR, the time limit for any Class will be 3 hours after the actual start of that Class.
- 14.2 Boats failing to finish within the time limit or 30 minutes (60 minutes for handicap cruisers & MOCRA) after the first boat sails the course and finishes whichever is later will be scored DNF without a hearing. This changes RRS 35, A5.1 and A5.2.
- 14.3 Should no boat finish within the Time Limit, the result of the race for that class may be determined from a previously recorded time for all boats (taken at the finishing line or rounding mark). This changes RRS 35, A5.1 and A5.2.

15 **PROTESTS**

- 15.1 RRS 60 applies with the following change; boats under 6m which are not required to display a Red Protest Flag but shall inform the Race Officer immediately after finishing that they wish to bring a protest. Protests must be submitted in writing within the time limits set out in RRS 60.3. Advisory Hearings and/or the RYA Arbitration Procedure may be available in accordance with the protocol available at the organising Club(s).
- 15.2 The Jury will hear protests in approximately the order of receipt as soon as possible.
- 15.3 Protest notices will be posted within 30 minutes of the protest time limit to inform competitors where and when there is a hearing in which they are parties to a hearing or named as witnesses.
- 15.4 RRS 63.7(b)(2) is changed to 60 minutes.

16 **SCORING**

- 16.1 RRS Appendix A, the low point scoring system will apply, unless the Class Rules state otherwise.

17 **OFFICIAL BOATS**

- 17.1 Craft owned by the organising clubs will normally be used; if private craft are used they will identify themselves to competitors.

18 **SUPPORT BOATS**

- 18.1 Unless providing help to any person or vessel in danger (RRS 1.1), team leaders, coaches and other support personnel shall not be in the racing area from the time of the Preparatory Signal for the first Class to start until all boats have finished or the Race Committee signals a postponement, general recall or abandonment. The penalty for failing to comply with this requirement will be the disqualification of all boats associated with the support personnel involved.

19 **TRASH**

- 19.1 Trash may be placed aboard support or official boats.
- 19.2 The penalty for breaking RRS 47, Trash Disposal, is at the discretion of the protest committee (DPC) and may be less than disqualification.

20 **RADIOS AND MOBILE PHONES**

- 20.1 The use of VHF radio or mobile phones to gain information that may assist a boat to improve its position is not allowed. However unless modified in the NoR, all keelboat, cruisers & cruising multihulls shall carry a VHF radio & listen on Channel 77 so that safety & race management information may be passed. Failure to receive this information shall not be grounds for redress. This changes RRS 61.1(a). A back-up mobile phone on board for use in an emergency is strongly recommended. In the event of Ch 77 being unworkable, Ch 72 will be used.
- 20.2 RRS 37 (search & rescue instructions) is modified and Flag D with one sound signal will be used instead of Flag V.
- 20.3 Use of the code word "Code Red" may be used to signify an emergency during racing; until cancelled by the controlling station, radio silence should be observed by those not involved in the emergency. The name of the Club should also be used in the initial transmission.

21 **DECLARATIONS, RETIREMENTS, RESULTS & PRIZES**

- 21.1 Any boat, which crosses the Finishing Line and does NOT signify EITHER that she has retired OR that she is protesting in accordance with RRS 61.1(a) shall be deemed to have completed the race in accordance with the Sailing Instructions. Declarations are NOT required.
- 21.2 Boats retiring shall report their retirement to the organising Club at the earliest opportunity: BSC (01983 872237) - SVYC (01983 613268) - BHYC (01983 872289) - RVYC (01983 882325)
- 21.3 Results will be posted on the official Notice Board of the organising Club(s) & their websites.
- 21.4 Prize details are given in the Notice of Race.

22 **RISK STATEMENT**

- 22.1 Rule 3 of the Racing Rules of Sailing states: "The responsibility for a boat's decision to participate in a race or to continue racing is hers alone."
- 22.2 Sailing is by its nature an unpredictable sport and therefore inherently involves an element of risk. By taking part in the event, each competitor agrees and acknowledges that:
- a. They are aware of the inherent element of risk involved in the sport and accept responsibility for the exposure of themselves, their crew and their boat to such inherent risk whilst taking part in the event;
 - b. They are responsible for the safety of themselves, their crew, their boat and their other property whether afloat or ashore;
 - c. They accept responsibility for any injury, damage or loss to the extent caused by their own actions or omissions;
 - d. Their boat is in good order, equipped to sail in the event and they are fit to participate;
 - e. The provision of a race management team, patrol boats, and other officials and volunteers by the event organiser does not relieve them of their own responsibilities;
 - f. The provision of patrol boat cover is limited to such assistance, particularly in extreme weather conditions, as can be practically provided in the circumstances;
 - g. It is their responsibility to familiarise themselves with any risks specific to this venue or this event drawn to their attention in any rules and information produced for the venue or event and to attend any safety briefing held for the event;
 - h. Their boat is adequately insured, with cover, unless varied in the NoR, of at least £3 million against third party claims.

23. **PRIVACY STATEMENT**

- 23.1 The personal information you provide to the organising authority will be used to facilitate your participation in the event. If you have agreed to be bound by the Racing Rules of Sailing and the other rules that govern the event (the rules), the legal basis for processing that personal information is contract. If you are not bound by the rules, the legal basis for processing that personal information is legitimate interest. Your personal information will be stored and used in accordance with the organizing authority's privacy policy. When required by the rules, personal information may be shared with the RYA, your national authority and/or World Sailing. The results of the event and the outcome of any hearing or appeal may be published.

24. **SAFEGUARDING**

- 24.1 In the event of any safeguarding concerns during a Regatta, the nominated Welfare Officer of the lead Club shall be informed. Contact information for Club Welfare Officers and links to the lead Club's Safeguarding Policy are included in each NoR.

25. **ANTI - DOPING**

25.1 By entering a race, participants agree to follow RYA anti-doping rules. More details of RYA Sail Clean are available by clicking *here*.

Special Course 1

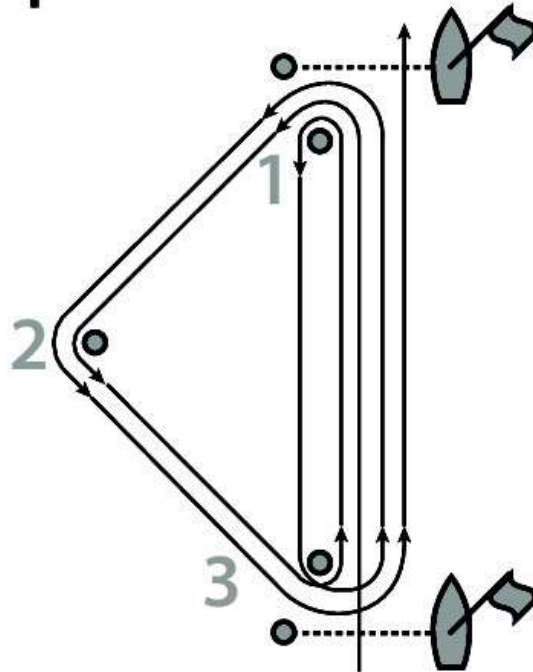

Start -1-2-3-1-3-1-2-3-Finish

*The Finish Committee Boat **may** be positioned between Marks 1 & 2.*

Special Course 2

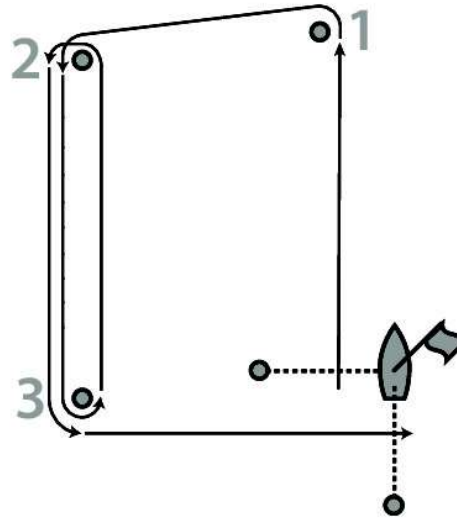

Start -1-2-3-2-3-Finish

Special Course 3

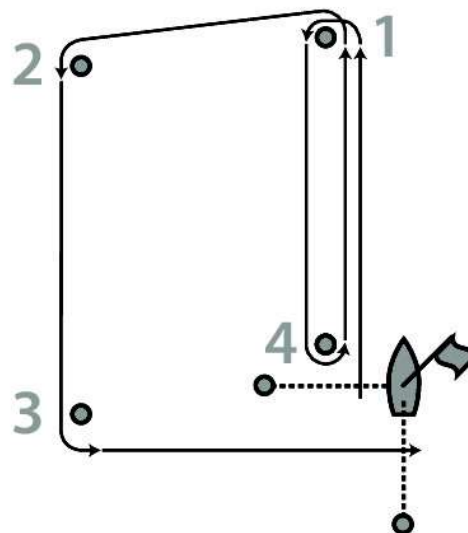

Start -1-4-1-2-3-Finish

Special Course 4

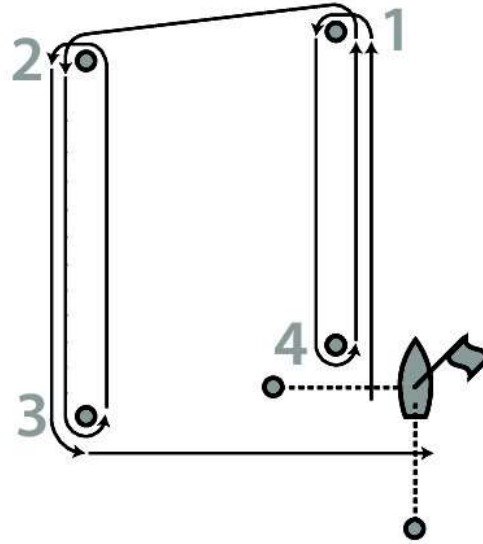

Start -1-4-1-2-3-2-3-Finish

Special Course 5

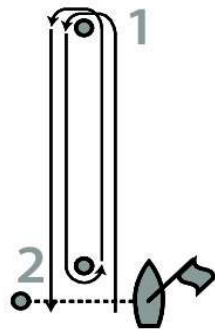

1 Round: Start -1-Finish

2 Rounds: Start -1-2-1- 2-Finish

Special Course 6

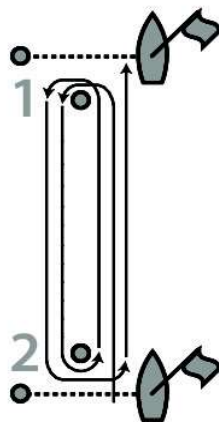

1 Round: Start -1-2-Finish

2 Rounds: Start -1-2-1- 2-Finish

The Start & Finish Committee boat may be positioned in the middle of the upwind leg

In the event of there being a leeward gate, boats must pass through it on the way to the finish line

Number of rounds indicated by the number of diamonds on a course board. The following course boards may also be used:

+W = Windward spreader

+L = Leeward spreader

+G = Leeward gate

The Start & Finish Committee boat may be positioned in the middle of the upwind leg

In the event of there being a windward gate, boats must pass through it on the way to the finish line

APPENDIX 2

EWCC RACING MARKS WITH ALLOTTED LETTERS, NUMBERS AND SYMBOLS		
A	ACLAND	Yellow Spherical/N Cone
B	BRITTEN	Yellow Spherical/Black Vertical Line
C	COCHRANE	Yellow Spherical
D	DRUMHEAD	Yellow Spherical
E	UNDER TYNE	Yellow Spherical
F	FITZWILLIAM	Yellow Spherical
G	GARLAND	Yellow Spherical with White Band
H	BRADING HAVEN TURNING MARK	Yellow Dan Buoy
I	NAB EAST	Red Channel Buoy
J	JONAH	Yellow Inflatable - Violet Top
JJ	JANSON (ex-PATCH)	Yellow Spherical with Black Band
jh	JENNY HUNTER	Yellow Spherical
K	DERRICK	Yellow Spherical with Orange Band
L	SEA VIEW LINE	Yellow Post
M	MORETON	Yellow Spherical with Orange Band
N	NAINBY LUXMOORE	Yellow Spherical
O	OLD CHURCH	Yellow Top Hat Buoy
Q	St HELENS	Red Channel Buoy
R	RUTHVEN	Yellow Spherical
S	LOLLIPOP	Yellow Inflatable - Yellow Top
T	TARA	Yellow Spherical
U	SOMERS	Yellow Spherical
V	BEMBRIDGE LEDGE	Yellow/Black East Cardinal
W	WRECK	Yellow Spherical
X	WARNER	Red Pillar Buoy
Y	FOOTPRINT	Yellow Top Hat Buoy
Z	NAB END	Red Pillar Buoy
!	NAB TOWER	Nab Tower
2	BRUCE	Yellow Inflatable - Orange Top
3	BERTIE	Yellow Spherical
4	PIERHEAD	Yellow Inflatable - Black Top
6	BROOKIE	Yellow Inflatable - Light Green Top
7	OUTER MARK	Yellow Spherical
8	LITTLE DEB	Yellow Inflatable - Mid-Blue Top
9	GORDON	Red Can
11	OLD 'O'	Yellow Top Hat Buoy
15	BOOM	Yellow Inflatable - Red Top
16	MAUDSLAY	Yellow Top Hat Buoy
22	TWENTY TWO	Yellow Inflatable - Brown Top
@	BOB	Red Dan Buoy
	BUNNY	Yellow Inflatable - Pink Top
ILM(10)	SVYC INNER LINE (Orange Start)	Orange Dan Buoy
	SPENCE WILLARD	Yellow Top Hat Buoy
#	PEPE	Yellow Top Hat Buoy
†	BEMBRIDGE TIDE GAUGE	
▲	INFLATABLE MARK TO WINDWARD [OPTIONAL 2 □s FOR A DISTANT MARK]	
▼	INFLATABLE MARK TO LEEWARD [OPTIONAL 2 □s FOR A DISTANT MARK]	
◀▶	INFLATABLE WING MARK	
+	LAID OUTER LIMIT MARK (COMMITTEE BOAT START/FINISH)	
£	BOATS MUST GO THROUGH THE FINISH LINE ON EACH ROUND	
+W	WINDWARD SPREADER MARK (Special Courses 5 & 6)	
+L	LEEWARD SPREADER MARK (Special Courses 5 & 6)	
+G	GATE MARK (Special Courses 5 & 6)	